



**CHESS**  
CONTROLS

INDUSTRIAL BATTERIES  
RACKS  
CONTAINMENT



## VRLA battery

The VRLA battery is short for valve regulated lead-acid battery, also sometimes called as the sealed lead-acid battery (SLA battery), a kind of lead-acid battery featured by the limited amount of electrolyte absorbed in a plate separator or formed into a gel. In all types of VRLA batteries, they have the same chemistry as the lead-acid batteries that contain two plates of lead to serve as electrodes and suspend in the immobilized electrolyte diluted sulfuric acid.

When it comes to discharging, the lead and diluted acid will have a chemical reaction and produce lead sulfate and water. Reversely, when the lead sulfate and water turn back into lead and acid, then it means it's on the charge. The charging current should match the capacity of the battery to absorb energy otherwise the damage will be caused to the battery and reduce its using life.

When high charging current happens, electrolysis will occur and decompose water into gases like hydrogen and oxygen. VRLA battery retains these generated gases within the battery if the pressure remains within a safe level and if the pressure exceeds the limits, then the safety valve will function and let the excess gases go and regulate the pressure back to normal. The safety valve function when the battery starts to build pressure of gases, namely when the battery is being recharged.

## Two Types of VRLA Battery

The VRLA battery contains two types of battery, AGM (Absorbent Glass Mat) battery, and Gel battery.

1. For the AGM battery, the electrolyte is suspended in the thin fiberglass mat and separates the plates. The advantages for AGM is that it can work in a various range of temperature condition and it is vibration-resistant so it's good to apply to mobile applications.
2. For Gel battery, the silica dust added to the electrolyte can form a thick putty such as gel. The difference between gel battery and AGM battery is the charge rate lower than the latter one. However, the gel battery can be widely used to hot temperature condition such as solar system to reach its full performance.

## VLA battery

The VLA battery is short for flooded vented lead-acid battery. Unlike the VRLA battery, it doesn't need a special pressure-relief valve. On the contrary, it utilizes a vent to allow gas to escape which in other words when choosing flooded vented lead-acid battery it needs to be vented the toxic hydrogen gas to the outside to avoid being trapped. The electrolyte it contained is free to move around in the battery encasement and the acid and lead plates to react to generate electricity.

## Differences Between VRLA and VLA Battery

1. The VRLA battery does not need frequent maintenance as there is no need to add distilled water to keep chemical reaction.
2. The sealed AGM or gel cell recharges faster than flooded vented lead-acid battery as the calcium added to the plates to reduce water loss.
3. All types of VRLA batteries can be mounted in any orientation while the VLA battery can only be installed upright due to the acid leaking.

4. The electrolyte in VRLA battery is immobilized while in VLA battery is moveable.
5. AGM battery performs better in self-discharging than tradition flooded lead-acid battery in terms of a wide range of temperatures.
6. Because of the feature of sealed and non spill, the VRLA battery can be made into small type and cater to portable electronics market.
7. The VLA battery is the most economic battery on the market. The price of VRLA battery is higher than flooded vented lead-acid battery. The AGM is twice higher and the gel battery is five times higher than the flooded vented one.
8. If the flooded vented lead-acid battery maintains properly, it can have longer lifespan than VRLA battery.

## LITHIUM-ION BATTERY

A lithium-ion battery or Li-ion battery is a type of rechargeable battery. Lithium-ion batteries are commonly used for portable electronics and electric vehicles. They're generally much lighter than other types of rechargeable batteries of the same size. The electrodes of a lithium-ion battery are made of lightweight lithium and carbon. Lithium is also a highly reactive element, meaning that a lot of energy can be stored in its atomic bonds. This translates into a very high energy density for lithium-ion batteries.

Contact us for price and availability at 705 682 2828

## RACKS AND CONTAINMENT

Battery racking solutions can be specified to accommodate any battery cell. From flooded to sealed, from vertical to horizontal mounting, a high density, space-saving rack.

### RACK SELECTION:

Length of rack =  $(X+5) \times$  No of block cells in a row

Where X = length of cell / block cell for length wise mounting

= width of cell / block cell for cross wise mounting

The value of length should be rounded off to nearest 100 mm and 5 mm.

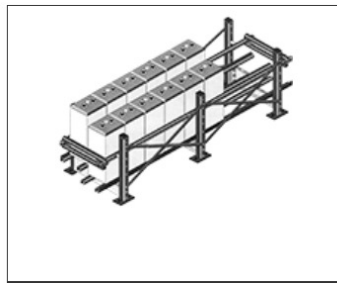

Tel. 705-682-2828

Toll Free 1-800-461-4076

Email [sales@chesscontrols.com](mailto:sales@chesscontrols.com)

[www.chesscontrols.com](http://www.chesscontrols.com)

# BATTERY RACK ARRANGEMENT

SINGLE TIER RACK  
1STEP 1TIER RACK

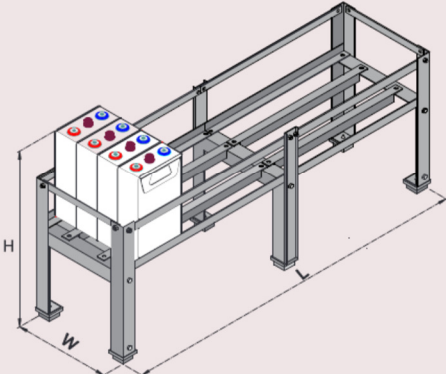

SINGLE TIER RACK  
3STEP 1TIER RACK

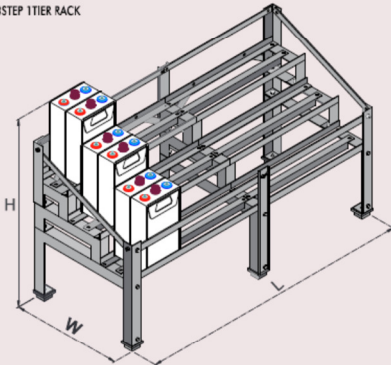

TWO TIER RACK  
1STEP 2TIER RACK

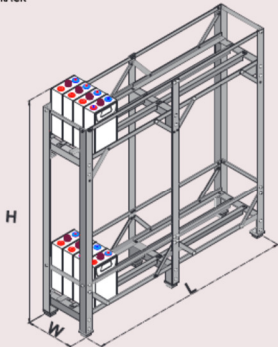

TWO TIER RACK  
3STEP 2TIER RACK

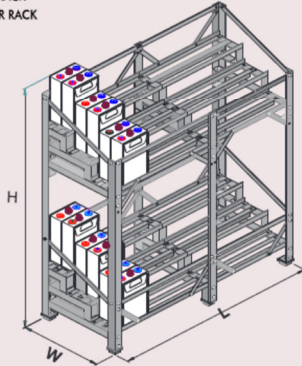

SINGLE TIER RACK  
2STEP 1TIER RACK

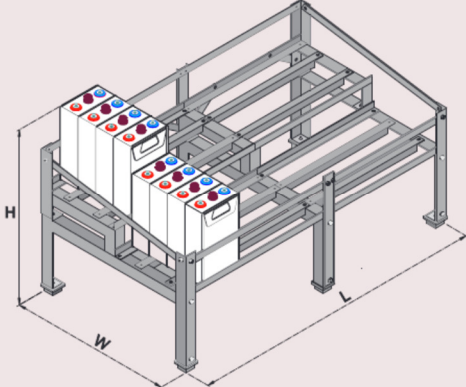

SINGLE TIER RACK  
4STEP 1TIER RACK

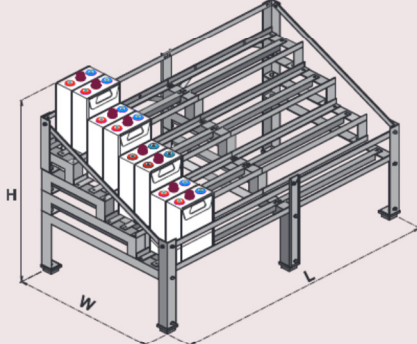

TWO TIER RACK  
2STEP 2TIER RACK

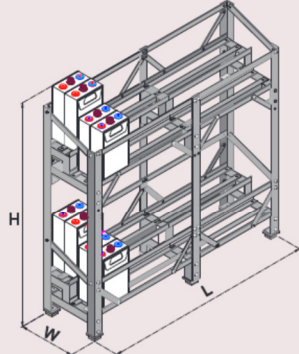

TWO TIER RACK  
4STEP 2TIER RACK

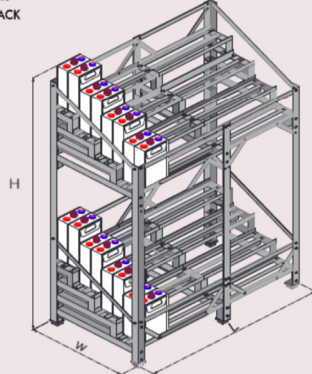

# BATTERY SPILL CONTAINMENT

Battery spill containment solutions are designed specifically for standby power applications. Many different spill containment solutions are available depending on your specific needs.



Contact us for more details at 705 682 2828



Tel. 705-682-2828

Toll Free 1-800-461-4076

Email [sales@chesscontrols.com](mailto:sales@chesscontrols.com)

[www.chesscontrols.com](http://www.chesscontrols.com)